

sPass DESFire reader

Contactless smart card reader



Features that make a difference:

- AES 128 bit encryption and 3DES (Triple DES) block cipher algorithm.
- Secure RS485 serial encrypted communications between sPass reader and DCM 350 or DCM 380 range
- Combats against card cloning and Wiegand signal controller cloning.
- Three on-board LED indicators to visually confirm/ deny entry.
- Built in Tamper.
- Built in Sounder.
- Suitable for indoor or outdoor applications.
- Available in Black or Gray.

The CEM sPass reader is a low cost, contactless smart card reader with powerful security and encryption features. The sPass reader utilizes 128bit AES and 3DES (Triple DES) encryption with highly secure DESFire technology. It is designed to be connected to the CEM DCM 350 or DCM 380 encrypted two-door controller, with encrypted RS485 serial communications between the sPass reader and the controller. Combined as one solution, the sPass reader and DCM 350 or DCM 380 controller range offers a cost effective solution which combats against the threats of card cloning and Wiegand controller signal cloning.

The sPass enclosure encapsulates all the electronics into one weather proof, durable and easy to install unit, making it ideal for both indoor and outdoor installations.

Bright LED's provide a visual indicator to confirm entry and an audible sounder provides clear feedback to the user.

For an extra layer of security the sPass reader is available as a keypad option which supports Card and PIN transactions (two factor authentication).

The sPass reader is designed for use with CEM's pre-personalized DESFire smart card. With a pre-personalized card memory, the CEM DESFire smart card holds up to 28 different security

applications. Using 3DES or AES 128 bit encryption, memory keys are securely stored on the DESFire smart card. No keys permanently reside within the sPass reader, with each card having uniquely encrypted keys for high levels of security.

Cost Effective

The sPass reader is a low cost reader that is designed for use with the CEM DCM 350 or DCM 380 secure two-door controller. It offers a cost effective controller solution for a high level of security.

Card Technology

The sPass reader features AES 128 bit encryption and Triple DES (3DES) card verification and RS485 encrypted serial data communications to the DCM 350 or DCM 380 controller. Both these features are essential to protect against developments in card cloning and Wiegand controller signal cloning.

Card cloning is the interception and replay of electronic communications from the card to the reader. Wiegand controller signal cloning is the recording or sniffing of the pulses (wired or wireless) between a card reader and its control panel.

Ease of Installation

The sPass reader is designed for simple installation. One cable delivers power and communications to the reader for ease of installation.

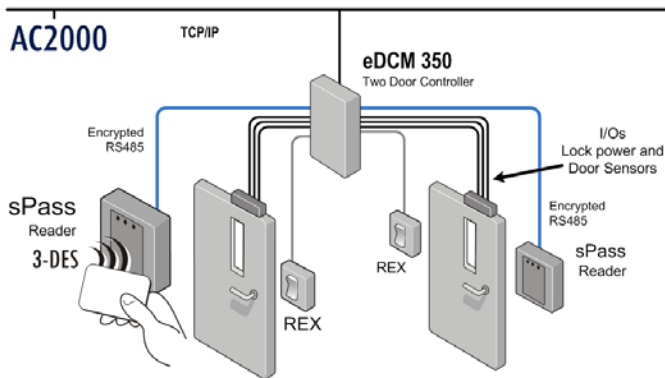

CEM sPass readers connected to an eDCM 350 two door controller in Master/Master & Master/Exit modes.

Specifications

Physical

Size 86 x 86 x 22mm (3.4" x 3.4" x 0.87")
 Weight 250g (8.8oz)
 Housing Flame retardant polycarbonate containing fully encapsulated electronics
 Color Black (Gray version also available)

Voltage

Voltage 9-15VDC
 Current Consumption 250mA (passive), 300mA (Peak)

Environmental

Temperature -10° to +55°C (14 ° to 122 °F)
 Indoor / Outdoor Both

The reader is designed to mount directly onto a standard UK or European (French) electrical containment box (American versions are provided with a compact adapter plate), meaning that standard conduit and fittings may be used.

Regulatory

Agency Certifications CE, R&TTE Compliant, Class A

Security

Encryption keys are secured in chips designed to zeroize if out of specification conditions are detected.

Supports card encryption with AES 128 bit encryption keys and Triple DES (3DES) block cipher algorithm. 32 bit to 128 bit card number output. 256 bit encryption between reader and controller

Tamper

Optical sensor will send alarm up to host system and trigger local sounder if the reader is disconnected from its mounting

Communication Interface

Card Transmit Frequency 13.56MHz
 Output Format To System Host RS485
 Termination One metre pig-tail
 Cable Distance 150 metres
 Recommended Cable Belden D 8723 E or equivalent stranded cable with overall shield. 2 pair minimum
 LED Indicators Three high intensity LED indicators, red, amber and green
 Keypad Optional. 12 character, standard layout, tactile response keypad
 Sounder Piezo-electric

Card Technology

A 13.56 MHz technology will allow the CEM sPass smart card reader to verify the unique ID of the following smart cards. The list is not exhaustive. For other card types please contact CEM Systems. (ISO14443A). The following cards are supported:

Card	Read Range
CEM DESFire	40mm (1.57in)
MiFare Classic	30mm (1.18in)

Requirements

- AC2000 v6.2 software & upwards
- AC2000 Airport v6.6 software & upwards
- AC2000 Lite v6.4 software & upwards
- DCM 350 or DCM 380 two door controller

Ordering Information

Product Code	Description
RDR/D10/101	Gray sPass DESFire reader with keypad
RDR/D10/100	Gray sPass DESFire reader with no keypad

Related Products



AC2000
AC2000 Airport
AC2000 Lite



DCM 350



DCM 380

Approvals



www.cemsys.com